

| | | |
|------------------------------|-------|---|
| 1、 INTRODUCTION: | ----- | 1 |
| 2、 ASSEMBLY: | ----- | 1 |
| 3、 ILLUMINATE: | ----- | 1 |
| 4、 PRECAUTION: | ----- | 1 |
| 5、 KEYPAD DEFINITION | ----- | 2 |
| 6、 OPERATION | ----- | 3 |
| 6.1 SWITCH ON | ----- | 3 |
| 6.2 ZERO | ----- | 3 |
| 6.3 TARE | ----- | 3 |
| 6.4 UNIT SWITCH | ----- | 4 |
| 6.5 SIMPLE COUNTING | ----- | 4 |
| 6.6 ACCUMULATION | ----- | 4 |
| 6.7 ACCUMULATION DISPLAY | ----- | 4 |
| 6.8 ACCUMULATION ELIMINATE | ----- | 4 |
| 7 FUNCTION OPERATION | ----- | 5 |
| 7.1 LINEARITY CALIBRATION | ----- | 5 |
| 7.2 OFFSET | ----- | 5 |
| 7.3 SINGLE POINT CALIBRATION | ----- | 6 |
| 7.4 TESTING | ----- | 6 |
| 7.5 FUNCTION SETTING | ----- | 7 |
| 8 ERROR MESSAGE | ----- | 7 |
| 9 COMMUNICATE FORMAT | ----- | 8 |

1、INTRODUCTION: ---

Thank you for purchasing a Hengx high resolution electronic scale. This scale enables you to measure the quality and weight. The scale is easy to operate, precise, stable and with fast display reaction. It is applicable in the electronic, hardware, plastic, medicine, textile and various other industries. It is useful for packaging, inventory and various production and quality control cases.

2、ASSEMBLE: ---

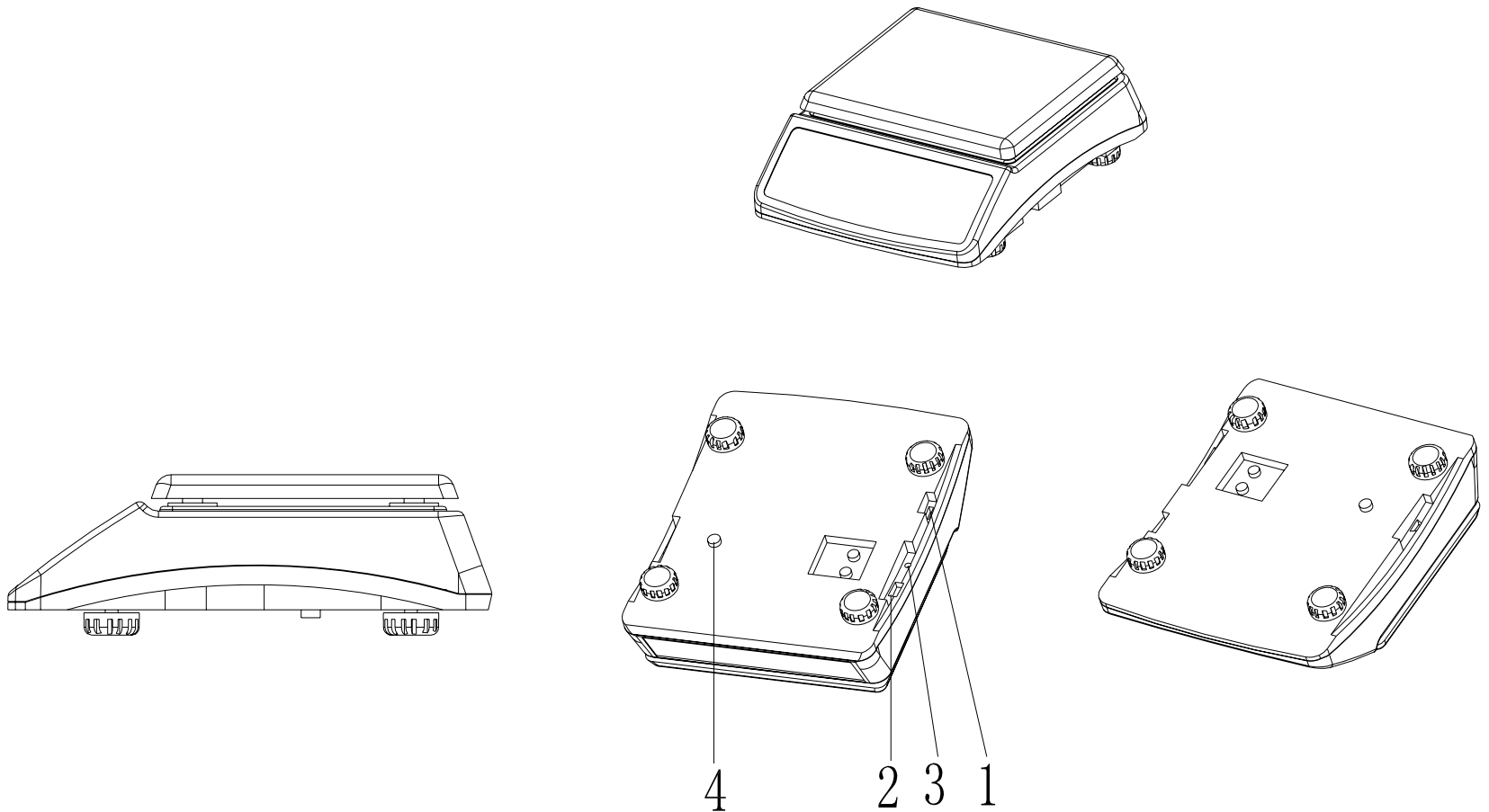

3、ILLUSTRATION: ---

- Assembly(please follow the sequence)
- Release and remove the protection screw 【4】 to resist the bottom housing
- Remarks: assembly the protection device 【4】 before transportation the scale. This is for protecting the scale.
- 【1】 power switch
- 【2】 RS-232 interface
- 【3】 DC power socket
- 【4】 shipping protection screw

4、Precaution: ---

1. full charge the battery after unpacking the scale
2. ***recharge the battery*:** when battery symbol appears on the LCD display, please plug in the power cord to charge the battery. The indicator of charge will light up in red. When it becomes green means charge completed.(it takes about 8 hours to full recharge the battery)
3. install the equipment on a level and stable surface.
4. do not install the equipment near the air condition or a vibrating machine.
5. please in the temperature of 0°C~ 40°C , prevent from rapid temperature changes
6. independent AC outlet for this equipment is recommended, check the voltage before plug in.
7. warm up the equipment for 15 minutes before use

5. KEYPAD : ---

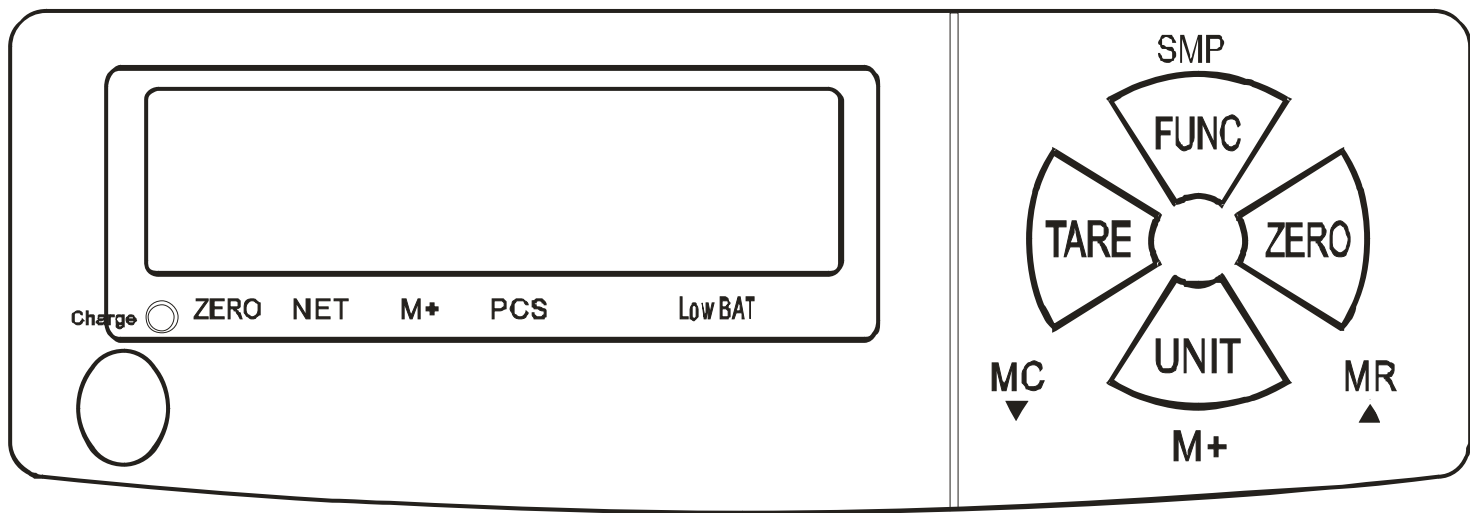

1)

A、 In the weighing mode: press this key, it only can come to zero when in $\pm 2\%$ of max weighing capacity
 In the tare mode, press this key can cancel tare and come back to zero, when tare is less than $\pm 2\%$ of max weighing capacity. When the tare is more than $\pm 2\%$ of max weighing, press this key can cancel tare, but could not come to zero.

B、 In the weighing mode, press **FUNC** and then press **MR** , is for accumulation display.

C、 in mode of PCS, press **FUNC** and then press **▲** , enter sample quantity selecting



2)

A、 It can only tare when in the stable weighing mode

Tare the weight of load on pan. 1

In the tare mode, press this key again to cancel tare.

B、 in the weighing mode, press **FUNC** and press **MC** , enter accumulation eliminate function

C、 in the mode of PCS press **FUNC** and press **▼** , enter sample quantity selecting



3)

A、 in the weighing mode, press this key and choose kg、 g、 lb、 oz、 tlh、 tlj、 tlt、 pcs in turn.

B、 in the weighing mode, press **FUNC** and press **M+** , to do weight accumulation

C、 in the PCS mode, press **FUNC** and press **SMP** , to do the sample function











4)

function conversion

6. OPERATION: ---

6.1 SWITCH ON: ---

| KEYPAD | FUNCTION |
|---|---|
|  | Shows 9, 8, ...0, version No., type and enter into normal weighing mode |
|  | Enter parameter setting |
|   | Enter linearity calibration |
|   | Enter single point calibration |
|    | Enter initial setting |

6.2 ZERO: ---

press  to zero

- ✧ range: when less or equal to $\pm 2\%$ of capacity
- ✧ in the tare mode, press this key to cancel tare
- ✧ press this key to cancel tare and come to zero

6.3 tare: ---

in the stable mode, press  to tare

- ✧ Can't work below zero(minus value) or above max capacity.
- ✧ After tare, display NET
- ✧ In the tare mode, press this key to cancel tare. Display zero, and stable symbol

6.4 units conversion ---

press  : kg, g, lb, oz, tlh, tlt, tlj and pcs conversion in turn

✧ Units conversion:

■ 1 lb = 453.59237 g

■ 1 oz = 28.349523125 g



6.5 simple counting function ---

- 1) in the PCS mode, press  to enter into quantity sample, shows XX pcs
- 2) place load on the pan
- 3) press ▲ or ▼, shows S 25pcs
- 4) press ▲ or ▼ constantly, choose 25 50、 100
- 5) press SMP, start counting function



6.6 accumulation ---

- 1) in the weighing mode, press  to enter accumulation function
- 2) press MR, do the accumulation function, shows ACC.XX, 1sec. later back to normal weighing mode
- 3) if accumulation with the same goods, must take away the goods first and after back to zero, place the goods on the pan.
- ✧ Could accumulation 10 times, if over, it will show: ACC.OV, 1sec. later back to normal weighing mode

6.7 accumulation display ---















- 1) press  to enter accumulation function
- 2) press MR, display total accumulation value, LCD displays ACC.XX, 1sec. Later display XXXXXX(accumulation value), press  back to normal weighing mode
- 3) total accumulation value over display range will show: OVER, 1sec. Later back to normal weighing mode

6.8 accumulation eliminate ---









- 1) press  enter into accumulation function
- 2) press MC, to do accumulation eliminate function, LCD shows ACC.00, 1sec. Later display 0(accumulation value), press  back to normal weighing mode
- when accumulation value over display range, it will show: OVER, 1sec. Later back to normal weighing mode

7. OPERATION: ---





7.1 linearity calibration function---

| STEPS | ILLUMINATE |
|-------|---|
| 1 |  press  to switch on the scale, LCD shows [CAL-L] |
| 2 |  press  , LCD shows [ON 0] to calibration zero point |
| 3 |  press  , waiting for LCD show [ON 1], place 1/3 of load |
| 4 |  press  , waiting for LCD show [ON 2], place 2/3 of load |
| 5 |  press  , waiting for LCD show [ON 3], place full load |
| 6 |  press  , waiting for LCD show [PASS] finish calibration |
| 7 |  press  back to normal weighing mode |







7.2 OFFSET: ---

| STEPS | ILLUMINATE |
|-------|--|
| 1 |  press  to switch on the scale, it shows [FUNSET] |
| 2 |  press  it shows [K X] |
| 3 |  press  again and it shows [XXXXXX] |
| 4 |  press  back to normal weighing mode |













7.3 SINGLE POINT CALIBRATION: ---

| STEPS | ILLUMINATE |
|-------|--|
| 1 | Press SMP to switch on the scale and LCD shows [ST 0] |
| 2 | press  it shows [ST 11] |
| 3 | press  , waiting for LCD show [ON 0] and calibration the zero point |
| 4 | Waiting for LCD shows [CAL-P] |
| 5 | Press SMP , choose the calibration point and place the equivalent weight |
| 6 | press  to start calibration and LCD shows [CAP] |
| 7 | Waiting for LCD shows [PASS], finish calibration |
| 8 | press  back to normal weighing mode |

7.4 TESTING: ---

| STEPS | ILLUMINATE |
|-------|---|
| 1 | press  to switch on and LCD shows [FUNSET] |
| 2 | press  again and LCD shows [K X] |
| 3 | press  , LCD shows kg |
| 4 | press  LCD shows g |
| 5 | press  and LCD shows lb |
| 6 | press  back to normal weighing mode |

7.5 FUNCTION SETTING: --- (underline words are the initial setting)

| STEPS | ILLUMINATE |
|-------|---|
| 1. |  press  to switch on the scale and start function setting, LCD shows [FUNSET] |
| 2. | LCD shows [0 ONOFF]in turn, backlight setting: ON/OFF/ <u>ONOFF</u> , press  to setting in turn |
| 3. | LCD shows [1 DE]in turn, resolution setting: DE/6000 or 7500/15000, press  to setting in turn |
| 4. | LCD shows [2 -1-]in turn, filter setting: 1, <u>2</u> , 4, 8, press  to setting in turn |
| 5. | LCD shows [3 D0] in turn, zero band setting: D0/ <u>D1</u> /D2/D3/D4/D5, press  to setting in turn |
| 6. | LCD shows [4 9600]in turn, band rate setting: 2400/4800/ <u>9600</u> , press  to setting in turn |
| 7. | LCD shows [9 PRT.CO]in turn, print mode setting: <u>PRT.CO</u> /PRT.ST, press  to setting in turn |
| 8. | LCD shows [E XX]in turn, units setting, press  to select in turn, press  : <u>ON</u> /OFF to setting in turn |
| 9. | LCD shows [F INT]in turn, initial unit setting, press  to setting in turn |
| 10. |  press  , back to normal weighing mode |

8. ERROR MESSAGE:

- 1) ERR3: over analysis area on A/D
- 2) ERR5: over load(max capacity +9e)
- 3) ERR6: over 10% of display weight when calibration
- 4) ACC.OV: over 10 times when accumulation
- 5) OVER: total accumulation over display range
- 6) Battery symbol: low battery
- 7) LOBAT: low voltage

9、*communicate format:*

RS-232 output format

Baud Rate : 2400、4800、9600

Data Bit :8

Parity : N(None)

P7 Stop Bit : 1

Code :ASCII

Data Format:

G=gross weight N=net weight

1、Kg

| | | | | | | | | | | | | | | | | | | | |
|-----|---|---|---|---|-----|--|--|--|--|--|--|--|--|--|--|---|---|----|----|
| G/N | . | W | . | : | +/- | | | | | | | | | | | k | g | LF | CR |
|-----|---|---|---|---|-----|--|--|--|--|--|--|--|--|--|--|---|---|----|----|

e.g.

G.W.:+2.2352kg

N.W.:+1.2352kg

2、g

| | | | | | | | | | | | | | | | | | | | |
|-----|---|---|---|---|-----|--|--|--|--|--|--|--|--|--|--|--|---|----|----|
| G/N | . | W | . | : | +/- | | | | | | | | | | | | g | LF | CR |
|-----|---|---|---|---|-----|--|--|--|--|--|--|--|--|--|--|--|---|----|----|

e.g.

G.W.:+2235.2g

N.W.:+1235.2g

3、lb

| | | | | | | | | | | | | | | | | | | | | |
|-----|---|---|---|---|-----|--|--|--|--|--|--|--|--|--|--|--|---|---|----|----|
| G/N | . | W | . | : | +/- | | | | | | | | | | | | l | B | LF | CR |
|-----|---|---|---|---|-----|--|--|--|--|--|--|--|--|--|--|--|---|---|----|----|

e.g.

G.W.:+4.928lb

N.W.:+4.928lb

4、oz

| | | | | | | | | | | | | | | | | | | | | |
|-----|---|---|---|---|-----|--|--|--|--|--|--|--|--|--|--|--|---|---|----|----|
| G/N | . | W | . | : | +/- | | | | | | | | | | | | o | z | LF | CR |
|-----|---|---|---|---|-----|--|--|--|--|--|--|--|--|--|--|--|---|---|----|----|

e.g.

G.W.:+78.844oz

N.W.:+78.844oz

5、Pcs

| | | | | | | | | | | | | | | | | | | | | | |
|---|---|---|---|---|---|-----|--|--|--|--|--|--|--|--|--|--|---|---|---|----|----|
| T | o | t | a | l | : | +/- | | | | | | | | | | | p | c | s | LF | CR |
|---|---|---|---|---|---|-----|--|--|--|--|--|--|--|--|--|--|---|---|---|----|----|

e.g.

Total:+645pcs